

# ANEMOMETER TRANSMITTER KIT

## INSTALLATION MANUAL

This manual describes how to install the Anemometer Transmitter Kit for a Wireless Vantage Pro2™ Weather Station. The kit enables you to connect the anemometer from your Integrated Sensor Suite (ISS) to its own transmitter, so it can be located away from the ISS and communicate directly with your console/receiver.

### Components

The Anemometer Transmitter Kit includes the following components and mounting hardware:

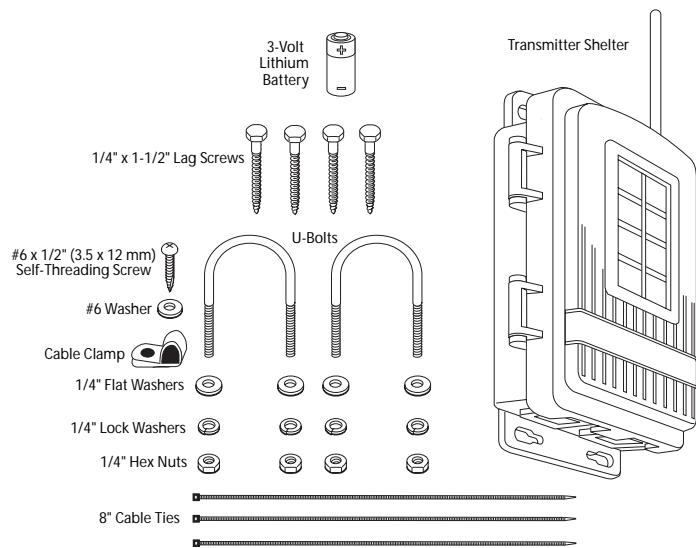

### Tools for Setup

In addition to the kit, you will need some or all of the following materials:

- Adjustable wrench or 7/16" wrench
- Compass or local area map
- Ballpoint pen or paper clip (small pointed object of some kind)
- Drill and 3/16" (5 mm) drill bit (if mounting on a vertical surface)
- Carpenter's level (if mounting on a vertical surface)

### If You Are Installing the ISS and the Anemometer Transmitter Kit at the Same Time

Install your ISS first, following the instructions in the ISS manual. However, during the step "Preparing the ISS for Installation," DO NOT connect the anemometer cable to the SIM. When you have mounted the rain collector side of the ISS and are ready to mount the anemometer, follow the instructions in this manual starting with "Preparing the Anemometer Transmitter" on page 3.

---

## Installation Steps

The following is an outline of the steps necessary to install the Anemometer Transmitter Kit. These steps are used as section headings in this manual and are explained in greater detail in the appropriate section.

- Remove the anemometer from its current location (if necessary)
- Disconnect the anemometer from the ISS transmitter
- Unfasten and remove the anemometer
- Prepare the anemometer transmitter
- Insert the battery
- Plug the anemometer cable into the transmitter
- Set the transmitter ID on the anemometer transmitter using DIP switches
- Set the console to recognize the signals
- View current wind data
- Putting your anemometer transmitter into TEST mode
- Choose a location for the anemometer transmitter
- Test transmission from the proposed mounting location
- Mount the anemometer and transmitter shelter in the new location
- A note on securing cables
- Troubleshooting
- Contacting Davis Technical Support

### Removing the Anemometer from its Current Location

The following two steps assume that your ISS is already mounted. If it is in a high location such as a rooftop, please read through the instructions before climbing up, and watch your balance while installing your Anemometer Transmitter Kit.

### Disconnecting Anemometer from ISS Transmitter

Open the SIM Box and unplug the anemometer cable from the receptacle labeled WIND on the SIM. Guide the anemometer cable through and free from the grommet. Or in the case of the Vantage Pro2 SIM Box, guide the anemometer cable free of the cable access port by first removing the foam insert and then guiding the cable out of the box. When finished, make sure to replace the foam insert ensuring that the Access Port is filled and free of any voids.

### If Your ISS is Mounted as a Single Unit (Both Sides Together on a Pole)

Unfasten the anemometer:

1. Remove the black rain collector cone from its base by rotating cone counter-clockwise until its latches line up with openings in the base and you can lift it off. It is much easier to reach the hex nuts with a wrench if you remove the rain collector cone first.
2. Using an adjustable wrench or 7/16" wrench, remove the hex nuts and washers holding the anemometer's plastic mounting base on the pole. Set the anemometer down for a moment.

3. Remove the hex nuts and washers holding the rain collector side on the pole. Retrieve the U-bolt that was holding the anemometer.
4. Using the washers and hex nuts, fasten the rain collector side back onto the pole. Flat washer goes on first, then lock washer, then hex nut.
5. Put the rain collector cone back on. Rotate the cone clockwise until the latches slide into place.

### If Your Anemometer is Mounted by Itself

Unfasten it: use an adjustable wrench or 7/16" wrench to remove the hex nuts or lag screws.

## Preparing the Anemometer Transmitter

The illustration below shows the Sensor Interface Module, or "SIM", inside the transmitter shelter.

1. Insert the 3-volt lithium battery into the battery holder, matching the "+" sign on the battery with the "+" sign on the SIM.
2. Push the end of the anemometer cable up through the square black grommet into the transmitter shelter. Every Davis shelter has two of these grommets to provide weather-resistant entrances for cables. In this case, use the grommet on the right. You can also remove the grommet, thread the cable through it and then replace the grommet in the shelter if that is easier for you.

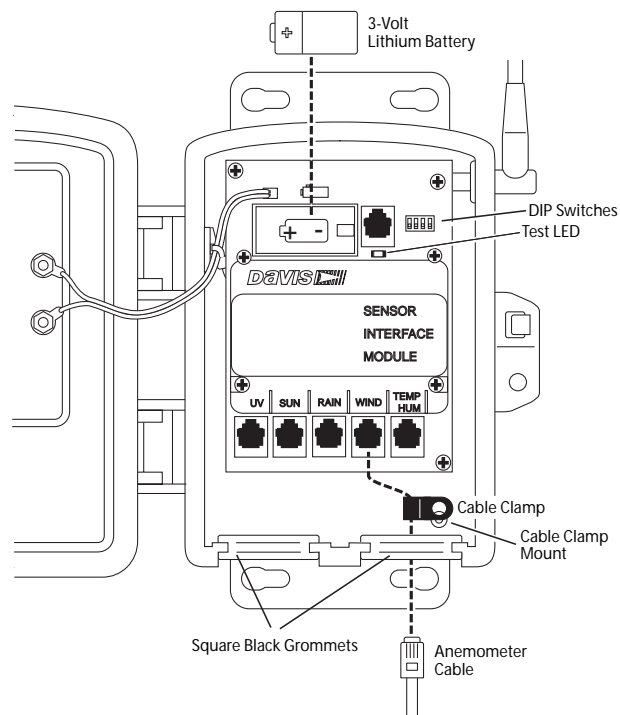

3. Plug the end of the anemometer cable into the receptacle labeled WIND on the SIM.
4. Place the cable clamp over the anemometer cable between the grommet and the receptacle. Secure the cable clamp to the shelter by threading the provided #6 screw through the washer, then cable clamp and then screwing it into the cable clamp mount inside the housing. (See the above illustration.)

---

5. Locate the DIP switches. You will work with them during the next installation step.

## Setting the Transmitter ID

Each wireless transmitting station must be set to one of eight transmitter IDs. DIP switches #1, 2 and 3 on the SIM allow you to control the ID — the “channel” the station will transmit on. (DIP switch #4 is used for transmission testing, not for transmitter ID.)

---

**Tip:** *The transmitter and your console communicate with each other only when **both** are set to the same ID.*

---

The factory default transmitter ID is ‘1’. Looking at the table below, you can see that means all three DIP switches are in the OFF position when each transmitting station leaves the factory, whether it is an ISS, an anemometer transmitter, or another kind of station.

The ISS is included with every Wireless Vantage Pro, and the console/receiver is factory set to find the ISS on ‘1’. **Since it is likely that your ISS is already set to ID ‘1’, you will need to set the ID of your anemometer transmitter to a different ID number. Use a ballpoint pen or paper clip to toggle DIP switches #1, 2, and 3.** The settings for transmitter IDs 1 – 8 are shown in the table below:

ID CODE	SWITCH 1	SWITCH 2	SWITCH 3
#1 (default)	off	off	off
#2	off	off	ON
#3	off	ON	off
#4	off	ON	ON
#5	ON	off	off
#6	ON	off	ON
#7	ON	ON	off
#8	ON	ON	ON

Use this table to ensure that each wireless transmitting station in your system is broadcasting on its own transmitter ID.

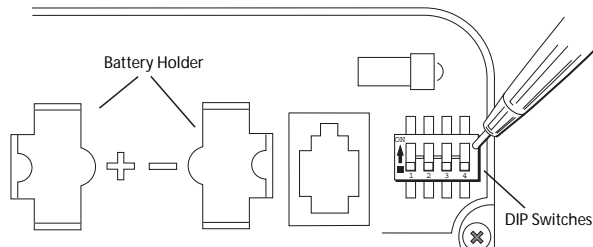

*DIP SWITCHES IN TOP-RIGHT CORNER OF SIM (ILLUSTRATION HAS BEEN ENLARGED FOR CLARITY)*

---

## Setting Console/Receiver(s) to Same ID

1. Put your console into Setup Mode — press and hold DONE and press the DOWN arrow (-). The console will show you Screen 1: Transmitters. You should see the words: “RECEIVING FROM...” and “STATION NO.” followed by the transmitter IDs that your console detects. One of these should be the ID number you just set on the anemometer transmitter. It may take one to two minutes for the station ID to appear. If you don’t see it, verify that you set the DIP switches correctly. If you still don’t see it, go to “Test Mode” on the next page.
2. Press DONE to move on to Screen 2: Selecting Transmitters. Setup Mode – Screen 2 is where you will set the console to recognize signals on that transmitter ID as coming from an anemometer transmitter.
3. Press the LEFT or RIGHT arrows to scroll through the transmitter IDs. When you see the ID you chose for the anemometer, press the UP (+) or DOWN (-) arrows to activate reception of that ID code. Make sure the screen shows “ON”.
4. Press GRAPH to change the type of station assigned to that transmitter ID. Press GRAPH until the word “WIND” appears.
5. To exit Setup Mode, press and hold DONE.

(For more information, see the **Vantage Pro2 User’s Manual & Setup Guide: “Setup Mode – Screen 2: Selecting Transmitters.”**)

**The console/receiver will display wind readings from one anemometer in the compass rose.** Once you set the ID code, it makes no visible difference that the readings are now being sent by the anemometer transmitter instead of the ISS transmitter.

## Viewing Current Wind Data

You should now see wind direction and speed displaying in the compass rose on the console screen. Press WIND if necessary to alternate between speed and direction. Spin the wind cups. Turn the wind vane, and allow 5 seconds for the wind direction display to stabilize before moving it again.

Display of current wind data confirms communication between your anemometer transmitter and the console. Go on to “Choosing a Location for the Anemometer Transmitter” on page 6.

## If You Do Not See Current Wind Readings

First, verify that the console/receiver is powered and is not in Setup Mode (exit Setup Mode by pressing DONE and holding it for a moment). Then, on the transmitter, ensure that the anemometer sensor cable is firmly plugged into the jack that is labeled WIND on the SIM. Check that the battery is properly installed. Walk around the room with the console, standing for a few moments in various locations to see if you are picking up signals.

If you don’t see wind readings no matter where you stand with the console, put your anemometer transmitter in Test Mode.

---

## Test Mode

DIP switch #4 on the SIM (see illustration on page 6) is the TEST DIP switch. Switch it to the ON position using a ball-point pen or paper clip. This puts the transmitter in Test Mode. An LED indicator light, located below the jack to the right of the battery on the SIM, will flash each time the transmitter broadcasts a signal, which should be every 2.5 seconds.

If the LED flashes only once and then remains dark, there is a problem with the anemometer transmitter. See “Contacting Davis Instruments” on page 11.

If the LED flashes repeatedly but your console isn’t picking up a signal anywhere in the room, it could be related to one of the following causes:

1. The DIP switches were not correctly set on the transmitter. Review the procedure on page 4.
2. The ID was not correctly set on the console/receiver. Review the procedure on page 5.
3. Reception is being disrupted by RF (radio frequency) interference. Interference has to be very strong to prevent the console from receiving a signal while in the same room as the anemometer transmitter!
4. There is a problem with the console/receiver. See “Contacting Davis Instruments” on page 11.

---

Note: Remember to **turn the Test DIP switch OFF** when you’re finished testing wireless transmission. If it is left ON, the blinking LED will reduce battery life significantly.

---

## Choosing a Location for the Anemometer Transmitter

Keep the following factors in mind as you choose a location for your anemometer and the transmitter shelter:

- Mount the anemometer at least 4’ (1.2 m) above the roofline for accurate wind readings. As shown in the ISS manual, the anemometer can be mounted on a pole or on a vertical surface such as a wooden post. It comes with 40’ (12 m) of cable to connect to the transmitter shelter.
- Mount the transmitter shelter nearby, with the solar panel facing the sun. In the Northern Hemisphere, position the transmitter shelter with solar panel facing south, for maximum sun exposure. (In the Southern Hemisphere, position the shelter with solar panel facing north.)
- If you need to increase the distance between your anemometer and the transmitter shelter, use extension cables #7876 from Davis Instruments. Please be aware that maximum wind speed reading decreases as the total length of cable from the anemometer to the ISS increases. If this distance is greater than 240’, maximum wind speed may be less than 100 mph.

---

Note: Not all cables are compatible with your Vantage Pro system. To be sure they will work, order extension cables from your dealer or directly from Davis Instruments.

---

---

## Range of Wireless Transmission

The range of your radio transmission depends on many factors. Try to position the transmitter shelter and your console/receiver as close as possible for best results.

Range is up to 1000' (300 m), line of sight, under optimal conditions. Typical range under most conditions is 200' to 400' (60 to 120 m), but this may be reduced by walls, ceilings, trees, or foliage. Radio-frequency interference (RF) can also reduce transmission distance. Cordless phones (900 MHz) and ham radios are common examples of RF interference.

A metal roof or other large metal structure can interfere with the signal (aluminum siding, a furnace with metal ducts, and your refrigerator are examples). Sometimes transmission between wireless units is obscured by something you cannot identify, or by some obstacle that you can't work around. If necessary, consider using **Wireless Repeater #7626 or #7627** to strengthen the signal or increase the distance between the anemometer transmitter and the console/receiver.

## Testing Transmission from Proposed Location

It is **very important** to test reception from the proposed location **before** permanently mounting the anemometer transmitter shelter.

Place the transmitter shelter at the intended mounting site, or have someone hold it there, so you can walk around with the console/receiver for a few minutes. Rotating the antenna may help to improve reception.

Test wireless reception anywhere you might want to use or mount your console/receiver now or in the future. Take your time. If you aren't picking up strong signals where you intend to place your console, better to move the transmitter shelter now than after it has been mounted. Experiment.

If you have irregular terrain in the area, it may interfere with the signal. For example, if the transmitter is mounted downhill from the console/receiver, the ground may block a wide angle of the transmitted signal.

## Mounting the Anemometer Transmitter

The anemometer can be mounted either on a pole or on a vertical surface such as a fencepost. Remember to mount it so the anemometer arm is extending northward. (Otherwise, you will need to re-orient the wind vane. See Appendix A in your ISS manual for instructions.) The transmitter shelter also can be mounted on a pole or on a vertical surface.

## Mounting Anemometer on a Pole

1. While holding the mounting base against the pole, place a U-bolt around the pole and through the two holes in the base.
2. Place a flat washer, a split washer and a hex nut on each of the bolt ends.

3. Swivel the anemometer until the arm is pointing north, if possible.
4. Using an adjustable wrench or 7/16" wrench, tighten the nuts. If the anemometer arm is not pointing north, follow the instructions in Appendix A in your ISS manual.

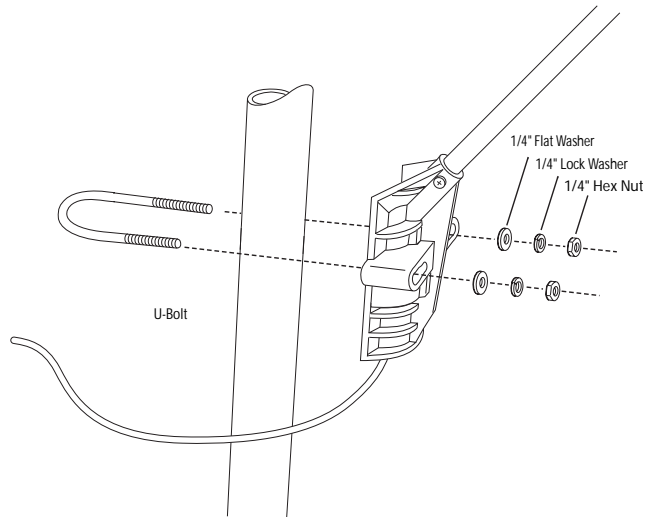

### Mounting Anemometer on a Vertical Surface

1. With a 3/16" (5 mm) drill bit, drill two holes approximately 2-1/8" (54 mm) apart. Use a carpenter's level to ensure the holes will be level.
2. Insert the 1/4" x 3" lag screws through the flat washers and the holes in the mounting base into the post.
3. Using an adjustable wrench or 7/16" wrench, tighten the lag screws. If the anemometer arm is not pointing north, follow the instructions in Appendix C in your ISS manual.

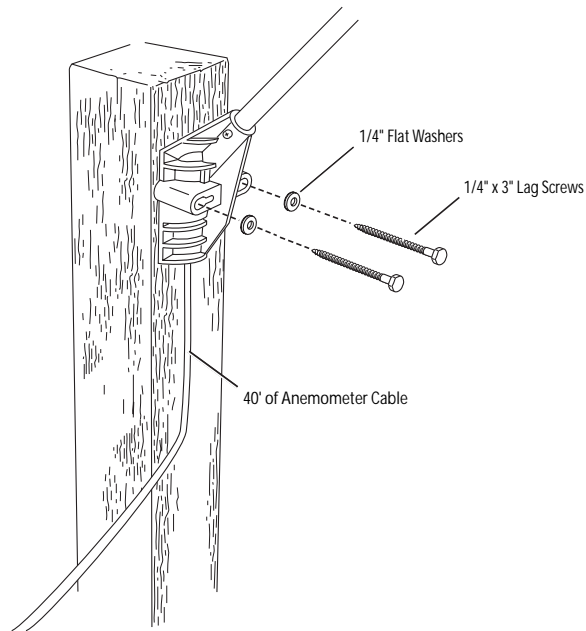

---

## Mounting Transmitter Shelter on a Pole

1. While holding the shelter against the pole, place a U-bolt around the pole and through the two holes on at the top of the shelter.
2. Place a flat washer, a lock washer and a hex nut on each of the bolt ends.
3. Using an adjustable wrench or 7/16" wrench, tighten the nuts.
4. Place the second U-bolt around the pole and through the two holes at the bottom of the shelter. Put a flat washer, a lock washer, and a hex nut on each bolt end, and tighten the hex nuts.

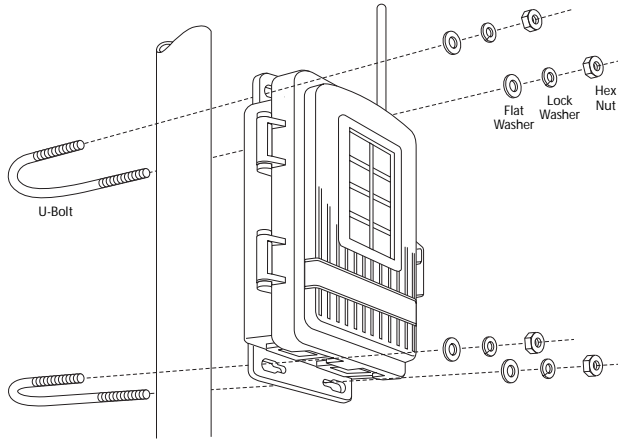

---

Note: Remember to position the shelter so the solar panel has maximum exposure to the sun.

---

## Mounting Transmitter Shelter on a Vertical Surface

1. With a 3/16" (5 mm) drill bit, drill two holes approximately 2" (50 mm) apart. Use a carpenter's level to ensure the holes will be level.
2. Drill two more holes 7-1/32" below the upper holes.
3. Insert the 1/4" x 1-1/2" lag screws through the flat washers, and through the holes at the top of the shelter into the post. Using an adjustable wrench or 7/16" wrench, tighten the lag screws.
4. Insert the 1/4" x 1-1/2" lag screws through the flat washers, and through the holes at the bottom of the shelter into the post. Using an adjustable wrench or 7/16" wrench, tighten the lag screws.

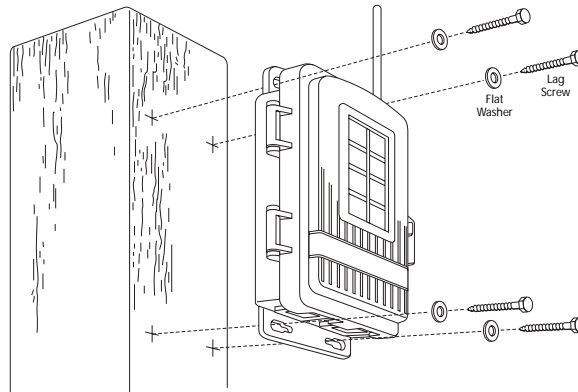

---

Note: Remember to position the shelter so the solar panel has maximum exposure to the sun.

---

---

## A Note on Securing Cables

To prevent fraying or cutting of cables, secure them so they will not whip about in the wind. Secure a cable to a metal pole by wrapping electrical tape around them both. Make sure cables are secure by placing clips or ties approximately every 3 – 5' (1 – 1.6 m).

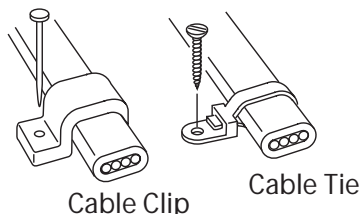

---

Note: Do not use metal staples or a staple gun to secure cables. Metal staples—especially when installed with a staple gun—have a tendency to cut the cables.

---

If you haven't used the entire length of anemometer cable, secure the remaining coil by taping it to the pole, or hanging it on a hook on the post. Place the coil at least 6" away from the antenna.

## Troubleshooting

### **“The anemometer head is tilted when I mount the anemometer.”**

With your Allen wrench, loosen the screws holding the anemometer head on the arm. (The screws are on the bottom of the anemometer head, by the wind cups.) Turn the anemometer head so it is straight and then tighten the screws.

### **“The wind cups are spinning but my console only displays zero miles/hour.”**

The signal from the wind cups is not making it back to the display. Loosen the set screw on the wind cup hub and be sure the hub is as close to the anemometer body as possible. It will drop a bit when you let go. Check your cables for visible nicks and cuts. Look for corrosion in the WIND jack on the Sensor Interface Module and on splices in the cable (if any). If possible, remove any extensions and try using the anemometer cable only. If none of these steps get the wind speed working, call Technical Support at (510) 732-7814 to ask for a wind test cable.

### **“The wind direction is stuck on north, or displays dashes.”**

It is likely that there is a short or break somewhere between the wind vane and the display. Check your cables for visible nicks and cuts. Look for corrosion in the “WIND” jack on the Sensor Interface Module and on splices in the cable (if any). If possible, remove any extensions and try with the anemometer cable only. If none of these steps get the wind direction working, call Technical Support at (510) 732-7814 to ask for a wind test cable.

### **“The wind cups don't spin as fast as they should. (Or don't spin at all!)”**

Either the anemometer is located where wind is blocked by something, or there is friction interfering with the cups' rotation. Friction usually can be remedied by the user — remove the wind cups and clear out any bugs or debris. Turn the shaft the cups rotate on. If it feels gritty or stiff, call Technical Support at (510) 732-7814. DO NOT LUBRICATE THE SHAFT OR BEARINGS IN ANY WAY.

---

When replacing the cups, make sure they are not rubbing against any part of the anemometer head.

**“Wind readings aren’t what I expected them to be.”**

Be very careful. Comparing to measurements from TV, radio, newspapers, or a neighbor is NOT a valid method of verifying your readings. Davis Instruments sensors are carefully tested at the factory. If you have questions, contact Technical Support.

## Contacting Davis Instruments

**(510) 732-7814** for Technical Support, Monday – Friday, 7:00 a.m. – 5:30 p.m. Pacific Time.

**(800) 678-3669** Toll-Free Order Line, Monday – Friday, 7:00 a.m. – 5:30 p.m. Pacific Time. Our customer service representatives can answer most questions and assist you with your purchases.

**(510) 732-9229** For callers outside the USA or Canada.

**(510) 670-0589** Fax to Customer Service or Tech Support.

**www.davisnet.com** Copies of User Manuals are available on the “Support” page. Watch for FAQs and other updates. Subscribe to the e-newsletter.

**support@davisnet.com** E-mail to Technical Support.

**sales@davisnet.com** E-mail to Customer Service.

**info@davisnet.com** General e-mail.

---

*Note: Please do not return items to the factory for repair without prior authorization.*

---

## Specifications

- Temperature range: –40 to 150° Fahrenheit (–40 to 65° Celsius)
  - Wireless transmission frequency: 902 - 928 MHz
- 868.0 - 868.6 MHz FHSS for overseas version – Product # includes “OV”
- Transmitter ID codes: 8 user-selectable
  - License: low power (less than 8 mW), no license required
  - Primary power input: Solar power – Davis solar charger
  - Secondary (backup) power: CR-123A 3-volt lithium battery or Optional Vantage Pro2 AC power adapter

---

## FCC Part 15 Class B Registration Warning

This equipment has been tested and found to comply with the limits for a class B digital device, pursuant to Part 15 of the FCC Rules. These limits are designed to provide reasonable protection against harmful interference in a residential installation. This equipment generates, uses and can radiate radio frequency energy and, if not installed and used in accordance with the instructions, may cause harmful interference to radio communications. However, there is no guarantee that interference will not occur in a particular installation.

If this equipment does cause harmful interference to radio or television reception, which can be determined by turning the equipment off and on, the user is encouraged to try to correct the interference by one or more of the following measures:

- Reorient or relocate the receiving antenna.
- Increase the separation between the equipment and receiver.
- Connect the equipment into an outlet on a circuit different from that to which the receiver is connected.
- Consult the dealer or an experienced radio/TV technician for help.

Changes or modifications not expressly approved in writing by Davis Instruments may void the user's authority to operate this equipment.

---

Product Numbers: 6332, 6332OV

Davis Instruments Part Number: 07395.237

Anemometer Transmitter Kit Installation Manual  
Rev. A Manual (10/15/04)

This product complies with the essential protection requirements of the EC EMC Directive 89/336.



3465 Diablo Avenue, Hayward, CA 94545-2778

510-732-9229 • Fax: 510-732-9188

E-mail: [info@davisnet.com](mailto:info@davisnet.com) • [www.davisnet.com](http://www.davisnet.com)